

The Crime Scene Sketch

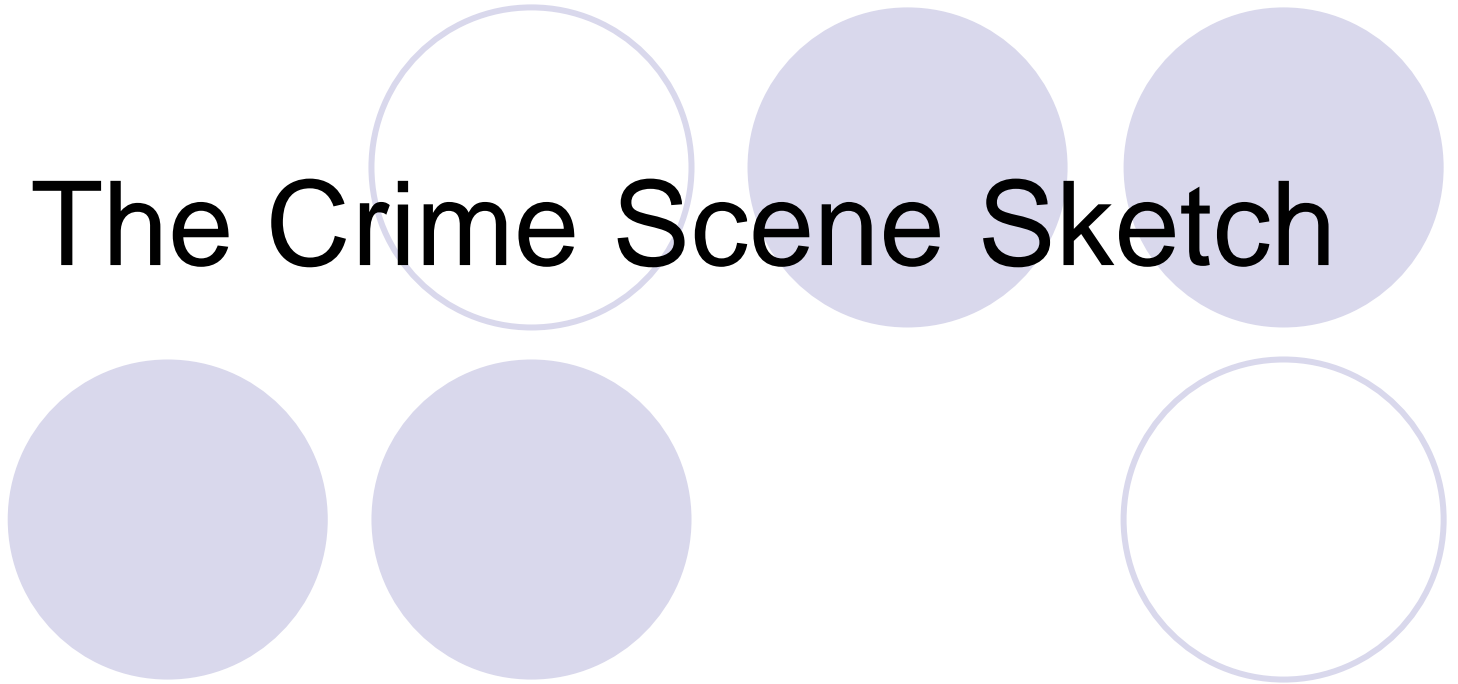

Introduction



- The crime scene sketch:
- Accurately portrays the physical facts
- Relates the sequence of events at the scene
- Establishes the precise location and relationship of objects and evidence at the scene
- Creates a mental picture of the scene for those not present
- Is a permanent record of the scene

Overview



- A crime scene sketch assists in:
 - 1) Interviewing and interrogating persons
 - 2) Preparing an investigative report
 - 3) Presenting the case in court
- The sketch supplements photographs, notes, plaster casts and other investigative techniques.
- Two types of sketches
 - Rough sketch
 - Finished or scale sketch

The Rough Sketch

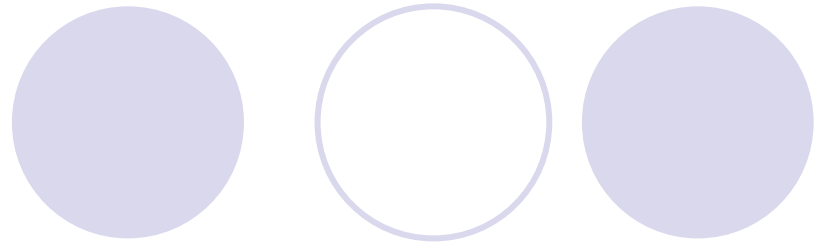

- The rough sketch is the first pencil-drawn outline of the scene and the location of objects and evidence within this outline.
- Usually not drawn to scale
 - Although distances are measured and indicated in the sketch
- Sketch after photographs are taken and before anything is moved.
- Sketch as much as possible.

Sketching Materials

- Paper
- Pencil
- Measuring tape
- Ruler
- Clipboard
- Eraser
- Compass

Steps in Sketching the Crime Scene

- Observe and plan
- Measure distances
- Outline the area
- Locate objects and evidence within the outline
- Record details
- Make notes
- Identify the sketch with a legend and a scale

Measure and Outline Area



- A steel tape is best
 - It doesn't stretch
- Use conventional units of measurement
 - Inches
 - Feet
 - Centimeters
 - Meters

Measure and Outline Area



- **North should be at the top of the paper.**
- **Determine Scale**
 - Take the longest measurement at the scene and divide it by the longest measurement of the paper used for sketching.
 - $\frac{1}{2}$ " = 1' small rooms
 - $\frac{1}{4}$ " = 1' large rooms
 - $\frac{1}{8}$ " = 1' very large rooms
 - $\frac{1}{2}$ " = 10' large buildings
 - $\frac{1}{8}$ " = 10' large land area



Measure and Outline Area

- **Measure from fixed locations**

- Walls

- Trees

- Telephone poles

- Corners

- Curbs

- Outlets

- Any Immovable Object

Plot Objects and Evidence



- Plotting methods are used to locate objects and evidence on the sketch.
- They include the use of:
 - Rectangular coordinates
 - A baseline
 - Triangulation
 - Compass points.

Rectangular Coordinates

Uses two adjacent walls as fixed points as distances are measured at right angles

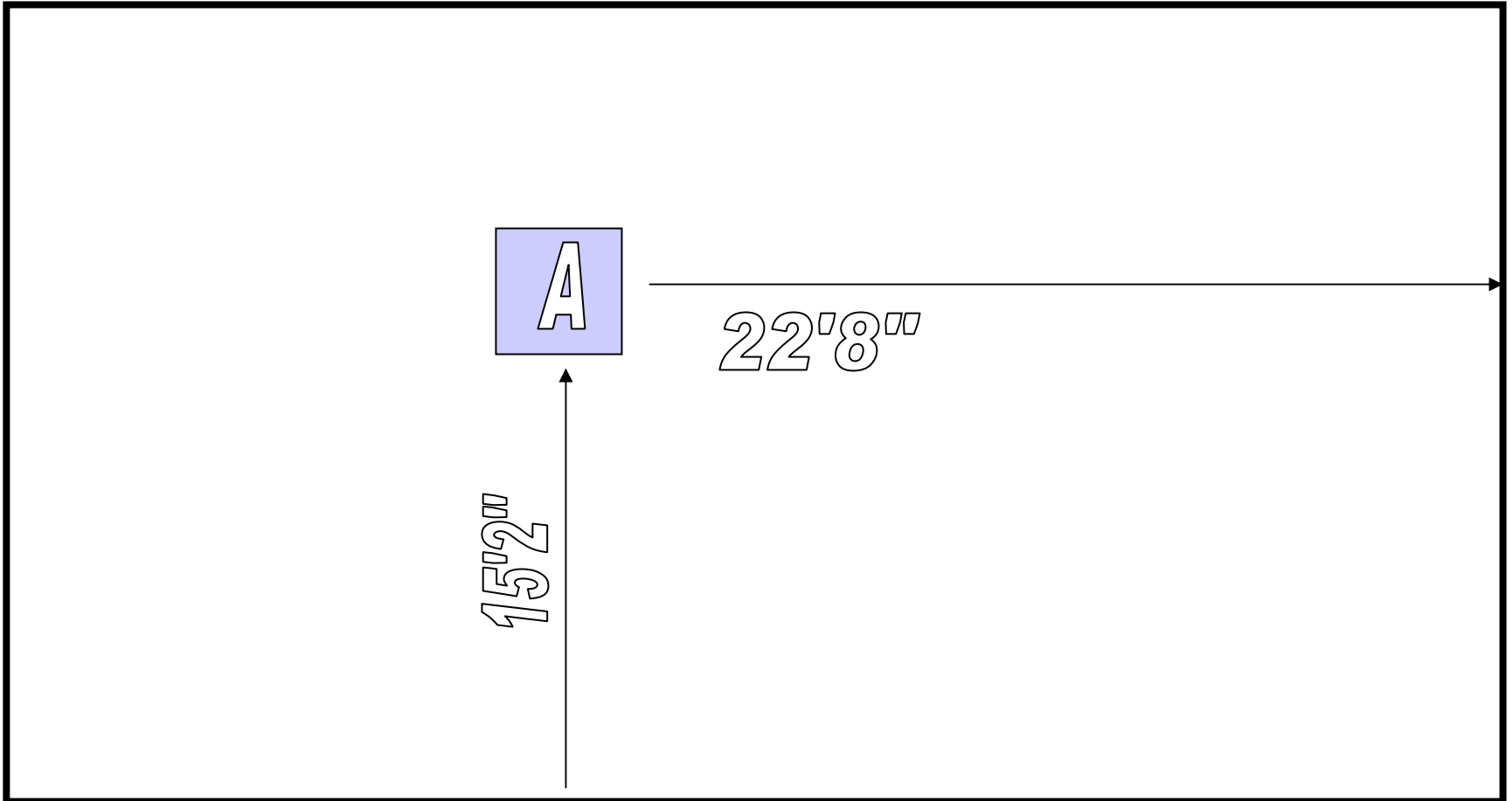

Baseline Method

- Run a baseline from one fixed point to another, from which measurements are taken at right angles.

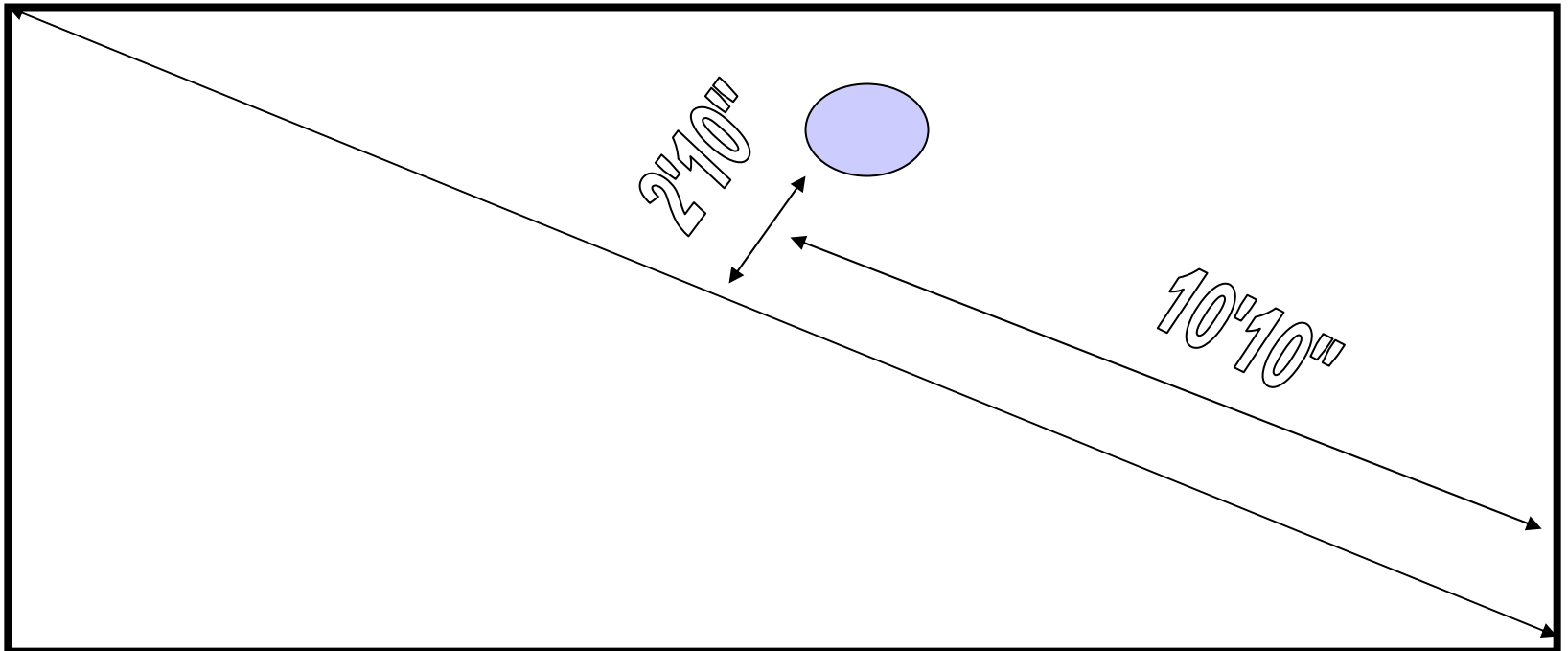

Triangulation

- Common in outdoor scenes
- Uses straight-line measurements from two fixed objects to the evidence to create a triangle with evidence in the angle formed by two straight lines.

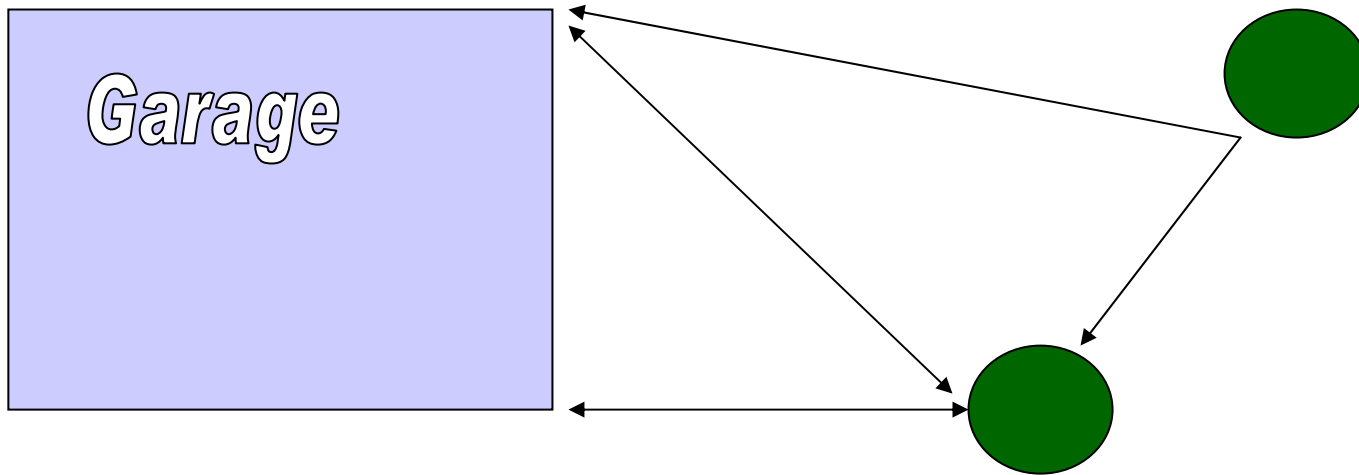

Compass Point Method

- Uses a protractor to measure the angle formed by two lines

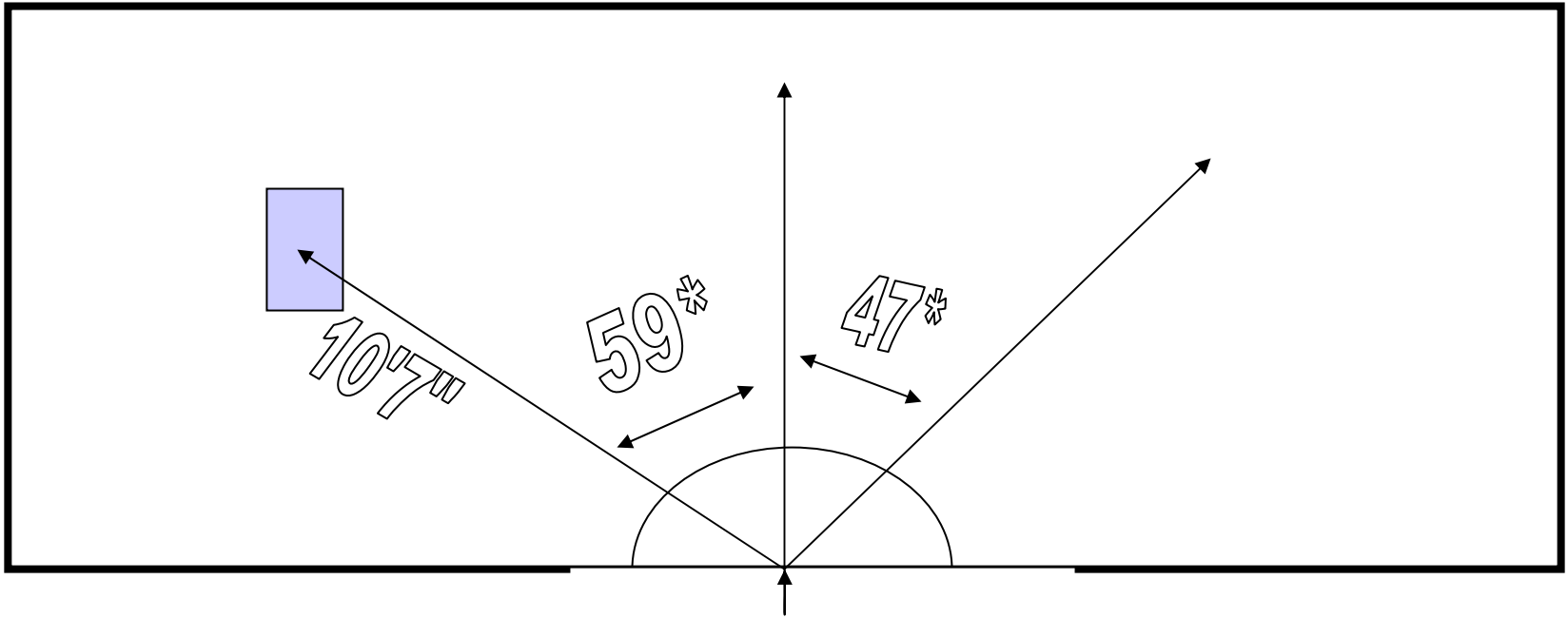

Cross-Projection Method

- Presents floors and walls as they were on one surface.

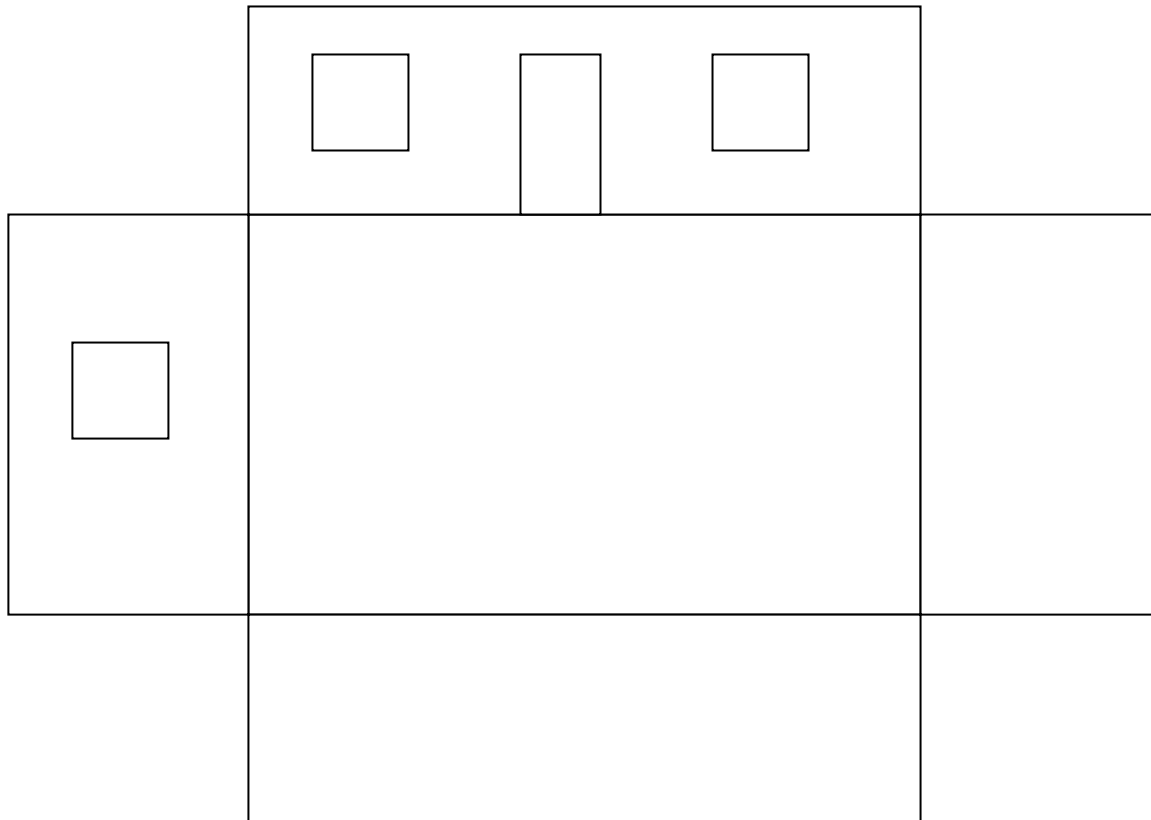

Make a Legend

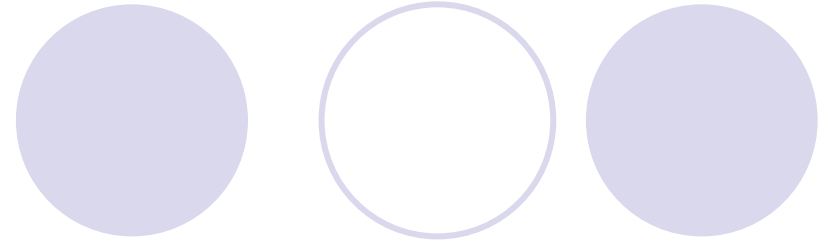

- Contains:

- Case number
- Type of crime
- Investigator
- Persons assisting
- Direction of North
- Identifying information in sketch - Key
- Scale